

Natural Ventilation of a Generator Room



Figure 1 An example of large scale louvre deployment in civil engineering

Task Objectives

Jesmond Engineering Ltd. was contacted for an engineering assessment of the exchange of temperature in a passively cooled environment. A full wall louvre system, similar to that illustrated in Figure 1, was to be used to facilitate airflow around a room containing an electrical generator.

Computational Fluid Dynamics (CFD) was used to ascertain whether the proposed design was capable of meeting imposed operating constraints.

This required Jesmond to construct an accurate CFD Model which could solve for the velocities of the turbulent flow and determine the capabilities of the airflow to transfer heat away from the generator. The capacity to consider various combinations of external flow conditions, air temperatures and generator temperatures was required.

Natural Ventilation

Natural ventilation is the process supplying and removing air from an indoor space without the use of mechanical systems and is considered a significant engineering challenge in industry.

Typically, natural ventilation is considered through two key mechanisms: wind-driven and buoyancy-driven flows. The former relies upon differences between indoor and outdoor static pressures generating a resultant through flow. The latter arises through differences in fluid density – typically due to an imposed temperature gradient – and is a phenomenon known as the *Stack Effect*.

Computational Fluid Dynamics

A CAD model was constructed, as illustrated in Figure 3. The model was parameterised such that the pitch of the louvre blades could be altered with respect to the inlet flow to ascertain the sensitivity to directional changes in airflow.

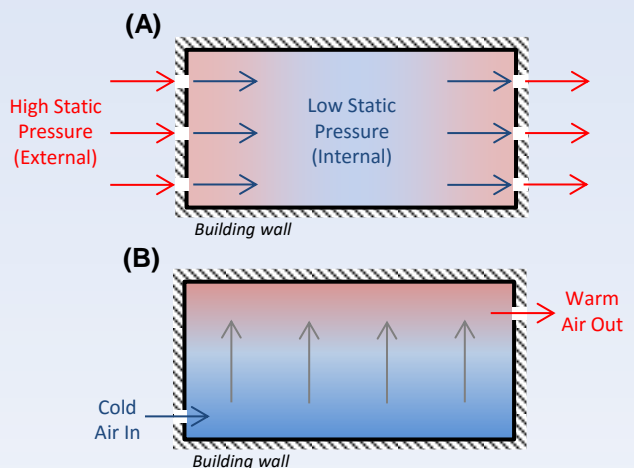

Figure 2 Schematics of airflow under primarily (A) wind-driven and (B) buoyancy-driven mechanisms

Continued overleaf

Case Study: Natural Ventilation of a Generator Room

The CFD system utilised both wind and buoyancy driven mechanisms for heat exchange. Examples of the temperatures of the exterior air, interior air and generator used in the model are 10° C, 20° C and 60° C respectively, whilst an example external wind speed is 4 metres per second.

The flow was ascertained to be turbulent from the Reynolds number calculation and so a K-Omega turbulent model was utilised. The geometry was meshed in full 3D using hexahedra cells, with a mesh density of circa 2.1 million cells. Initial boundary conditions were computed and the simulation was conducted using an in-house high performance server.

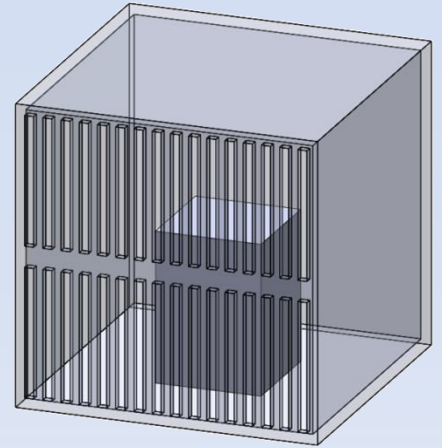

Figure 3 Mock CAD model of the proposed building design, with the implementation of a full wall louvre system.

Simulation Results

Figure 4 demonstrates the general pattern of airflow using particle streamlines, with cross-sectional slices demonstrating the corresponding heat flux. Heat flow is more clearly represented in Figure 5, demonstrating the rapid dispersion from the generator surfaces towards the upper outlet region.

The simulation results were shown to mirror client expectations from previous designs. While buoyant effects were evident, wind-driven ventilation was shown to be the primary form of heat dispersion from the generator. The client had previous concerns with the design about localised heat spots behind the generator, however the CFD simulation demonstrated the average wind speed was capable of passively cooling all surfaces of the generator.

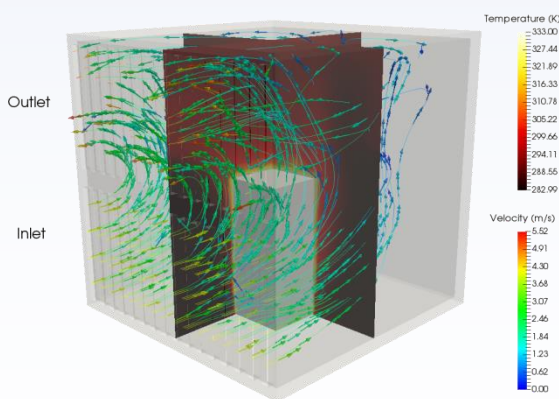

Figure 4 CFD simulation results, demonstrating cross-sectional slices for temperature and particle streamlines for airflow velocity

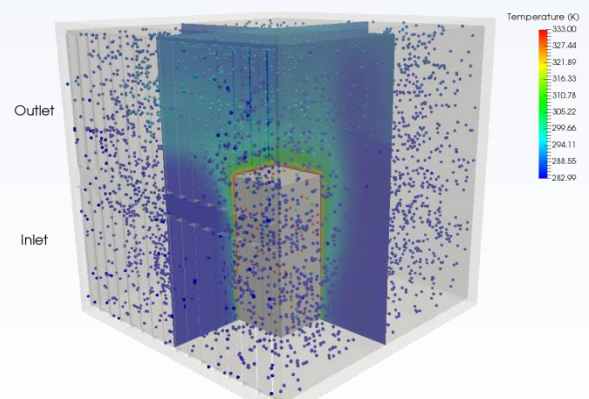

Figure 5 Temperature "glyph" plot illustrating the dispersion of heat to the outlet via wind and buoyancy driven means